

Fuel and Exhaust (Group 3)

Carburetor Rebuilding and Restoration Service

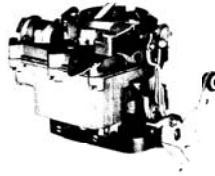

Each carburetor is totally disassembled and cleaned in a hot tank solution. Then, each component is correctly plated, painted and colored to duplicate it's original factory finish. The carburetor is reassembled using all proper gaskets, pumps, needles and seats, etc. and new correct screws. Finally, all bench adjustments are made to factory specs. This includes correct shimming of the start switch. The result, the best rebuilt and restored carburetor available in the Hobby.

NOTE: This is not an area to skimp on your restoration. Demand the best!

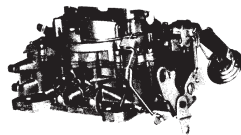
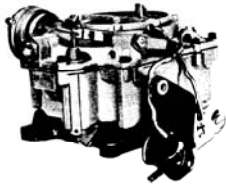

- 1961-1972** All 2bbl Carburetors w/ Bakelite switch
CRS-390\$325.00 ea.
- 1961-1972** 4bbl. Carburetor rebuilding service.
CRS-520\$379.00 ea.
- 1964-1966** All Carter 2 x 4 Sets
CRS-636D\$699.00 ea.

Carter Baffle Plate

1965-1966 GS with Carter AFB 4bbl. Stainless Steel Plate between carb. & intake manifold. This plate is essential for protection against disintegration of aluminum base of carb. It is also necessary for proper idle and smooth running. Recommended is gasket, baffle plate, gasket.
BP-576.....\$14.50 ea.

Choke Stove Pipe Replacement Kit

- 1961-1967**
All as required.
CSK-530.....\$15.00 kit

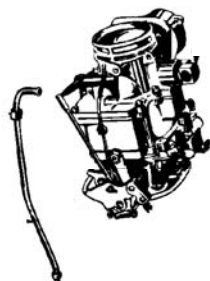

Carburetor Kits

Carter

- 1961-1967** All 4 BBL and 2-4 BBL. Numbers: 3088, 89, 3297, 3503, 79, 3633, 3635, 3665, 3826, 3827, 3921, 22, 23, 4053, 54, 55, 56, 59, 60, 61, 4179, 4180, 81, 4331, 4332, 4344, 4453.
CKC-617.....\$25.75 ea.

Rochester

- 1961-1963** All 215 V8, 4BBL.
Numbers: 7020043, 045, 7023044, 045.
CKR-613.....\$34.00 ea.
- 1961-1965** All 215, 300 and 364, 2BBL. Numbers: 7019042, 090, 093, 7020146, 147, 7023046, 047, 142, 7024046, 047, 7025046, 047.
CKR-615.....\$29.50 ea.
- 1964** 300 V8, 4BBL. Numbers: 7024044, 7024045.
CKR-64.....\$34.00 ea.
- 1964-1965** All Rochester 1bbl.
CKR-645.....\$43.50 ea
- 1965-1966** 401 V8, 4BBL. Numbers: 7023040, 7023143, 7024040, 7025040, 7025140, 7026040.
CKR-636.....\$25.25 ea.
- 1966 (Early)** 400, 401, 425;
1967 400, 430, 4BBL. Numbers: 7026240, 242, 7027146, 147, 148, 149, 7027240,241, 7036240, 7036242.
CKR-667.....\$29.50 ea.
- 1966-1969** 300, 340, and 350 V8, 2BBL. Numbers: 7026046, 047, 146, 147, 7027044, 045, 046, 049, 7028140, 7028141, 7029140, 141, 7036046, 048, 146, 248, 7037034, 7037044, 17054649.
CKR-669.....\$25.25 ea.
- 1967** Late; With 400, 430 and 455 engines. 4MV 4BBL. Numbers: 7027244, 246, 248, 7041304, 305, 306, 307, 308, 309.
1968-1972 Numbers: 7028240, 242, 243, 246, 247, 248, 7029240, 241, 242, 243, 7029246, 7040240, 7040243.
CKR-670.....\$25.25 ea.
- 1968-1974** 350, 455, 4BBL. Numbers: 7028244, 245, 7029244, 245, 7040244, 245, 7041245, 7041544, 7042244, 245, 944, 7043244, 245, 246, 7044244, 246, 544, 7044546, 17054900, 901, 902.
CKR-684.....\$23.00 ea.
- 1970-1972** 455 HI-PERF, 4BBL. Numbers: 7040246, 247, 7041242, 243, 540, 7042240, 242, 243, 940, 7042942, 7043240, 242, 243, 7044240, 241, 252, 540.
CKR-702.....\$25.75 ea.
- 1970-1974** 350 and 455, 2BBL. Numbers: 7040142, 143, 148, 444, 446, 7041142, 143, 442, 7042142, 7042143, 842, 7043142, 143, 7044141, 142, 144, 442, 7044444, 17054651, 17055003, 17057350, 351.
CKR-704.....\$23.75 ea.

Stromberg

- 1961 All. WW 2 BBL #7-14.
CKS-61\$49.00 ea.

Fuel and Exhaust (Group 3)

Intake Manifold Gaskets (3.270)

1961-1963 All V-8. Large Metal Valley Pan.
 IMG-613.....\$23.50 ea.

1962-1963 All 198 V-6 Engines.
 IMG-623.....\$15.00 ea.

1964 All 300 Engines.
 IMG-64.....\$13.75 ea.

1964-1967 All 225 V-6 Engines.
 IMG-647.....\$15.00 ea.

1965-1967 All 300 Engines.
 IMG-657.....\$13.75 ea.

1965-1966 All GS-400.
 IMG-576.....\$10.75 ea.

1966-1967 All 340 Engines.
 IMG-667.....\$15.00 ea.

1967-1971 All 400, 455 Engines.
 IMG-671.....\$32.50 ea.

1968-1972 All 350 Engines.
 IMG-685.....\$36.50 ea.

1972 All 455 Engines.
 IMG-726.....\$27.00 ea.

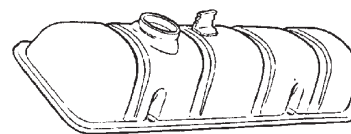

Valve Cover / Intake Manifold Ventilation Grommets

1963-1974
 1963-1967: Valve Cover, All;
 1967-1974: Intake Manifold, All.
 VG-634\$ 6.50 ea.
1964-1967 All. Solid Rocker Cover Plug.
 CP-647\$9.50 ea.
1970-1974 Valve Cover (Rubber).
 VG-704\$3.75 ea.

Ask About Chrome Plating Your Rocker Covers!



GF-636A

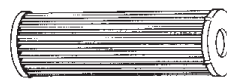

GF-682



GF-636

Accelerator Pedals



1964-1967 All. Correct ribbing and ball sockets, and cut-out at top for throttle rod exactly as original.

GP-647\$13.50 ea.

1968-1972 All.
 GP-682\$15.00 ea.

Pedal Return Spring

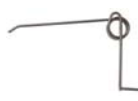

1968-1972 All.
 PS-682.....\$7.50 ea.

Pedal Rod Pin



1968-1972 All.
 PR-682.....\$4.50 ea.

Gas Filters /Elements

<u>CARS#:</u>	<u>YEARS:</u>	<u>APPLICATION:</u>	<u>PRICE:</u>
GF-602	1961	All with AC	~~~~~\$ 9.25
GF-572	1961-1962:	All without AC	~~~~~\$ 7.75
GF-627	1962-1967:	1962-1967 all v-6 1966 GS 400 with A.T. without A.C. (this is a "stone" element)-----	\$7.25
GF-636A	1962-1966:	All with AC,	~~~~~\$ 11.50
GF-636	1963-1966:	All without AC	~~~~~\$ 10.50
GF-675	1967:	All V8;	
	1968-1972:	All L-6	
	1968-1972:	All V8 w/ 2 Bbl.Carb.~~~~~	\$ 3.25
GF-682	1968-1972:	All V8 w/ 4 Bbl. Carb. ~~~~~	\$ 3.25



All years replacement. Clear in-line Gas filter. Great for near gas tank or frame installation. Important for insuring clean fuel to fuel pump.
 GF-100.....\$9.50 ea.

Fuel and Exhaust (Group 3)

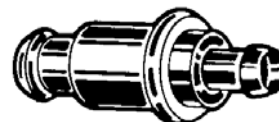

PCV Valve

CARS#:	YEARS:	APPLICATION:	PRICE:
PCV-637	1963-1967:	V-6 ~~~~~	\$ 4.75
PCV-635	1963-1972:	All V8 ~~~~~	\$ 4.50

PCV Valve Clamp

CARS#:	YEARS:	APPLICATION:	PRICE:
HC-100W	ALL	on PCV Hose ~~~~~	\$ 1.00

PCV Valve Grommet

CARS#:	YEARS:	APPLICATION:	PRICE:
VG-634	ALL	~~~~~	\$ 6.50

Breather Tubes

(Air Cleaner to Rocker Cover)

Breather Tube

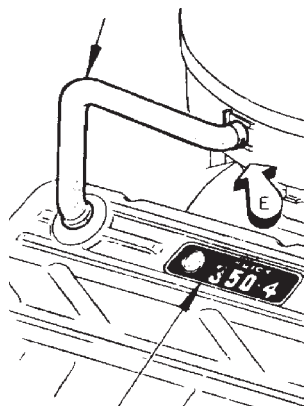

1968-1969 All 350 and 400 4BBL.
VT-689\$16.00 ea.

1970-1971 all V-8; 1972 all 455
engines
VT-704.....\$13.75 ea.



Pinch Clamps (corbin clamps)

For fuel lines, vacuum lines & PCV hoses

CARS#:	YEARS:	APPLICATION:	PRICE:
PC-380	All	3/8" OD hose ~~~~~	\$ 1.00
PC-716	All	7/16" OD hose ~~~~~	\$ 1.00
PC-150	All	1/2" OD hose ~~~~~	\$ 1.00
PC-916	All	9/16" OD hose ~~~~~	\$ 1.00
PC-580	All	5/8" OD hose ~~~~~	\$ 1.00
PC-1116	All	11/16" OD hose ~~~~~	\$ 1.25
PC-340	All	3/4" OD hose ~~~~~	\$ 1.00
PC-100	All	1" OD hose ~~~~~	\$ 1.25

Dash Pots

1961-1963 All with 4 BBL carburetors.

DP-613\$ 14.50 ea.



1961-1971

1961-1963: All V-8, 2 BBL;
1962-1963: All V-6 with Auto trans.;
1965-1971: All with Auto trans.

DP-611\$ 14.50 ea.

Ported Vacuum Switch (2.410)



1968-1972 All 8 Cylinder Except 1972 3
Port 2 Terminal Switch.

PVS-684.....\$ 79.50 ea.

Choke Pull-Offs

(3.755)

(For rochester 4bbl Carburetors)

1968-1974 All 350, 400, 455 Engines. Front or Rear
CPO-684\$11.50 ea.

1971 All 455. Rear
CPO-71\$17.50 ea.

1972-1974 All 350 & 455 Engines. Rear.
CPO-724\$19.00 ea.

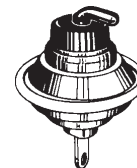

Rod Clips

1961-1966 Carburetor throttle rod clip.
1/4" rod diameter.

RC-460\$0.50 ea.



Fuel and Exhaust (Group 3)

GS Ram Air Foam Seals

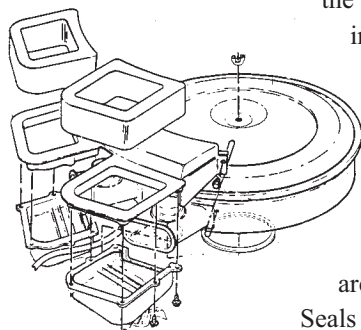

Our seals are manufactured just as the originals. They have gray inner foam surrounded by dark gray outer skin.

1969-1971 models use 2 square seals. 1972 models use one square and one triangular seal.

Seals for 350 cid. engines are 2 5/8" high.

Seals for 455 cid. engines are 2" high.

1969-1971 GS-350.

- RAS-691\$27.50 pr.
- RAS-691C.....(Concourse Correct)\$65.00 pr.

1969-1971 GS-400 and GS-455.

- RAS-691B.....\$27.50 pr.
- RAS-691BC.....(Concourse Correct)\$65.00 pr.

1972 GS-350.

- RAS-72\$27.50 pr.
- RAS-72C.....(Concourse Correct)\$65.00 pr.

1972 GS-455.

- RAS-72B.....\$27.50 pr.
- RAS-72BC.....(Concourse Correct)\$65.00 pr.

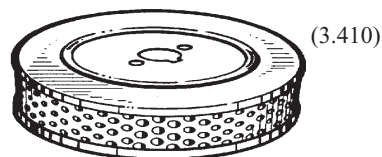

Air Filters

CARS#: YEARS: APPLICATION: PRICE:

6 Cylinder

AF-625 1962-1972: All ~~~~~\$ 11.00

8 Cylinder

AF-607 1961-1967 All V-8 exc. 1967 GS ~~~~~\$13.00
 AF-646 1965-1966 GS w/ 2 X 4bbl carbs ~~~~~\$24.50
 AF-636 1965-1966: 400 (4 Bbl.) ~~~~~\$18.25
 AF-67 1967: GS-340 ~~~~~\$18.25
 AF-625 1968: 350 (2 Bbl.) ~~~~~\$11.00
 AF-680 1968: All with (4 Bbl.)
 1969-1972: All GS; All 455 ~~~~~\$11.00
 AF-698 1969-1972: 350 Eng. Exc. GS ~~~~~\$11.00

Air Cleaner Wing Nuts

CARS#: YEARS: APPLICATION: PRICE:

WN-530 1961-1970: Air Cleaner Wing Nut
 (1/4" -20 Thread) ~~~~~\$ 1.75
 WN-710 1971-1972: Air Cleaner Wing Nut
 (5/16" -18 Thread) ~~~~~\$ 1.75



Air Cleaner Vacuum Motor

1968-1972 all as required.

- VM-694L.....(fits L.H. side of snorkel).....\$23.75 ea.
- VM-694R.....(fits R.H. side of snorkel).....\$23.75 ea.



Crankcase Ventilation Filter On Side Of Air Cleaner

1968-1972 All.

- CVF-682\$ 4.25 ea.

Throttle Cables

1968-1971 thru 1971 all 400 and 455 engines.

- TC-681.....\$39.00 ea.

Fuel and Exhaust (Group 3)

Fuel Pumps

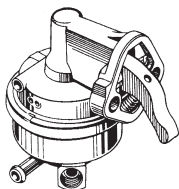

<u>CARS#:</u>	<u>YEARS:</u>	<u>APPLICATION:</u>	<u>PRICE:</u>
FP-613RS	1961-1962 All; 1963 all V-6;	1963 V-8 1st type w/ Pump # 4827 (Rebuilding Service only)	~~~~~\$ 78.50
FP-635	1963:	215 Engine Pump #40001;	
	1964-1965:	225, 300 Engine	~~~~~\$ 43.00
FP-575	1965:	GS	~~~~~\$ 38.50
FP-66S	1966:	225, 300, 340 Engine	~~~~~\$ 59.50
FP-66	1966:	400 without air conitioning	~~~~~\$ 65.00
FP-67	1967:	225, 300, w/o. AC; All 340 4bbl	~~~~~\$ 49.50
FP-67A	1967:	300, 340 2 Bbl. w/. AC	~~~~~\$ 38.00
FP-685	1968-1972:	350 w/o. AC	~~~~~\$ 37.50
FP-682A	1968-1972:	350 with AC	~~~~~\$ 37.50
FP-684	1968-1972:	250 Engine	~~~~~\$ 32.00
FP-674	1967-1969:	400 Eng (Except STAGE 1);	
	1970-1972:	455 (Except GS)	~~~~~\$43.00
FP-683	1969-1970:	455 GS /STAGE 1;	
	1971-1972:	GS	~~~~~\$ 54.50

Fuel Pump

Block-Off Plates

1961-1972 All as Required.

CP-300.....\$10.50 ea.

Fuel Pump Cam

*Mounts on Camshaft
to Operate Fuel Pump*

1961-1972 All 225, 300, 340 & 350 engines.

FPC-615\$24.50 ea.

Fuel Pump Hardware Kits

1965-1966 all 400,401,425 engines. Correct bolts/washers

FPH-406\$4.50 ea

Fuel Pump Rebuilding Kits

1961-1963

1961-1962: All Pump #4827;

1963: All V-6.

FPK-613\$42.50 ea.

1965 GS 400.

FPK-575\$38.00 ea.

1963-1965

1963: All 215 Engines;

1964-1965: All 225, 300 engines #4001, 1 pump.

FPK-635\$32.50 ea.

Electric Fuel Pump

1961-1972 All. 12V Universal

Replacement Pump.

FP-12\$75.00 ea.

Fuel Lines

Fuel Pump to Carburetor

CARS#: YEARS: APPLICATION: PRICE:

FL-350 1968-1972: All 350-4 ~~~~~\$ 26.50

FL-455 1968-1972: 400, All 455-4 ~~~~~\$ 26.50

FL-455S 1968-1972: STAGE 1 455 ~~~~~\$ 26.50

FL-70 1970: All 4 Bbl. Carburetors ~~~~~\$ 26.50

Fuel Line Clip Sets

**Correct Style in Correct Colors (used in conjunction
with our Brake Line Clip Sets)**

1964-1965 all with 5/16" line.

FLC-645.....No return..1 pc.....\$2.25 ea.

FLC-645W.....With Return.9 pc.....\$7.75 set

1964-1967 all with 3/8" line.

FLC-647.....No Return.1 pc.....\$2.25 ea.

FLC-647W.....With Return.9 pc.....\$7.75 set

1968-1969 all with 3/8" line. With Return

FLC-689.....8 pc.....\$6.50 set

1970 all with 3/8" line.

FLC-70.....No Return. 4pc.....\$4.50 set

FLC-70W.....With Return. 10 pc..... \$11.00 set

1971-1972 all with 3/8" line.

FLC-712.....4 pc.....\$14.00 set

1971-1972 all with 1/4" 5/16" EMS

FLC-712E.....8 pc.....\$15.50 set

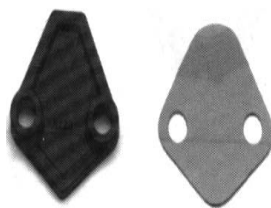

Fuel & Exhaust (Group 3)

Exhaust Headers

Our headers are custom made for their specific applications and legal for off-highway use only. Available in Metallic Ceramic Coating or uncoated. Collector size is 3". All headers come with collector reducers, all mounting hardware, premium gaskets and detailed instructions.

1968-1972 All 350 engines

EH-680C.....Ceramic Coated.....\$549.50 set
EH-680.....Uncoated.....\$399.50 set

1964-1972 All 400, 430, 455 engines

EH-648C.....Ceramic Coated.....\$649.50 set
EH-648.....Uncoated.....\$499.50 set

Brass Nuts. Tall. All years as required. 3/8-16. Used on manifolds, pipes, exhaust, trim etc. Solid Brass

N6P.....\$3.50 pair



FL-576

Exhaust Manifold French Locks



FL-626

1964-1966 GS-400 (6 per car) Stainless Steel

FL-576\$2.25 ea.

1964-1966 GS-400 (4 per car) ; 1966 225, 33, 340 engine as required. Stainless Steel

FL-626\$1.75 ea.

Exhaust Manifold Gaskets

1961-1963 All 215 V-8 Engines.

EMG-613\$12.75 pr.

1962-1967 All. 198 & 225 V-6 Engines.

EMG-627\$19.50 pr.

1964-1967 All 300 & 340 Engines.

EMG-647\$12.75 pr.

1965-1966 All 400Engines.

EMG-576\$10.75 pr.

1967-1972 All 400 & 455 Engines.

EMG-676\$14.50 pr.

1968-1972 All 350 Engines.

EMG-680\$16.50 pr.



Exhaust Clamps And Bolts

CARS#:	YEARS:	APPLICATION:	PRICE:
EC-214	All	2 1/4" U-Bolt ~~~~~	\$ 5.75
EC-134	All	1 3/4" U-Bolt ~~~~~	\$ 3.25
EC-178	All	1 7/8" U-Bolt ~~~~~	\$ 3.25
EC-200	All	2" U-Bolt ~~~~~	\$ 5.75
EC-214	All	2 1/4" U-Bolt ~~~~~	\$ 5.75
EC-212	All	2 1/2" U-Bolt ~~~~~	\$5.75

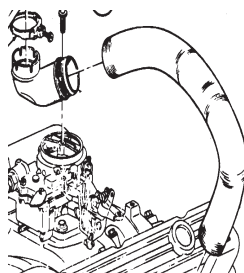

Exhaust Manifold Heat Pipe (Air Cleaner to Exhaust Manifold)

1970-1974 All

HP-704.....\$13.25 ea.

Rear Muffler Hangers



1964-1972 All models with dual exhaust.

MH-642L...Lefthand Side.....\$12.00 ea.

MH-642R.Righthand Side\$12.00 ea.



Tail Pipe Hangers

1964-1972 All models with dual exhaust. Fits either side.

TPH-642.....\$7.50 ea.

1971-1972 Exhaust Tips

1971-1972 All with N-25 Exhaust thru the Bumper Option. Chrome plated steel as original. Aprox. 2.25 id to allow room for stock 2" pipes.

EE-712\$249.00 pr.

Fuel and Exhaust (Group 3)

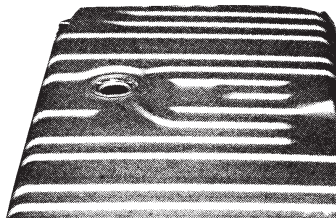

Gas Tanks

(for all cars exc. wagons)

- 1964-1967** Without vent. Does not come with filler neck. 21.5 gallon.
 GT-647\$199.00 ea.
- 1964-1967** With vent. Without filler neck. 20 gal.
 GT-647V\$199.00 ea.
- 1968-1969** All. Includes filler neck. 2 vents. 20 gal.
 GT-689\$209.25 ea.
- 1970** Without E.E.C. (1 Vent). Does not include filler neck. 20 gallon.
 GT-70V\$211.00 ea.
- 1970** Without E.E.C. (2 Vents). Does not include filler neck. 20 gallon.
 GT-70V2\$189.75 ea.
- 1970** With E.E.C. (3 Vents). Does not include filler neck. 20 gallon.
 GT-70V3\$196.00 ea.
- 1971-1972** All. Filler neck included. 3 vents. 20 gal.
 GT-712\$209.25 ea.

Gas Tank Straps

- 1964-1967** All. As original
 GS-647\$24.50 pr.
 GS-647S.....Stainless Steel.....\$69.50 pr.
- 1968-1972** All. As original
 GS-682\$24.50 pr.
 GS-682S.....Stainless Steel.....\$69.50 pr.

Gas Tank Caps (3.028)

- 1961-1963** All;
 1964-1970 All Wagons. Vented
 GC-575'\$7.25 ea.
- 1964-1970** All Exc. Wagons. Replacement Cap. Not vented
 GC-640\$7.25 ea.
- 1964-1970** All Exc. Wagons. (GM Style Cap)
 GC-640G\$7.25 ea.
- 1971-1972** All.
 GC-714\$9.50 ea.

Gas Tank Sealer/Liner

- Alcohol resistant. Quart Can.
 TS-1\$20.25 ea.

Gas Tank Etch

- Removes Light rust and will prep for sealer/liner. 16oz.
 TE-1\$12.75 ea.

Lead Additive

- All Buick Engines needing leaded gas.
 LA-1.....\$11.00 ea.

Gas Tank Bolt Kit

- 1961-1967** All as needed. Two 3/8-16 x 3" Bolts and two(2) lock nuts. Brightly zinc plated.
 GB-610\$5.25 kit

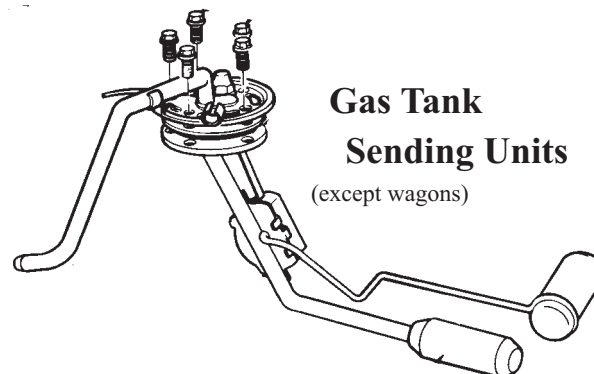

Gas Tank Sending Units

(except wagons)

- 1964** All with A.C. except wagons.
 SU-64A\$189.50 ea.
- 1968-1970** All 350 engines with single fuel lines.
 SU-680S\$124.75 ea.
- 1968-1970** All with dual fuel lines.
 SU-680.....\$199.00 ea.
- 1971-1972** All 350 engines with A.C. or dual fuel line;
1971-1972 All 455 engines.
 SU-712.....\$229.50 ea.
- 1971-1972** All 350 engines with single fuel line.
 SU-712S\$124.75 ea.

Sending Unit Gaskets

- 1961-1963** All;
 GG-355\$3.75 ea.
- 1964-1972** All;
 GG-642\$4.75 ea.