

BUICK PARTS: GROUP NUMBERS

Engine • Clutch • Decals.....	Group 0
Cooling • Oiling • Grills	Group 1
Electrical • Lamps	Group 2
Fuel • Carburetion • Exhaust	Group 3
Transmission • Brakes	Group 4
Wheels • Propeller Shaft • Rear Axle	Group 5
Front Suspension • Steering	Group 6
Frame • Springs • Shocks • Bumpers	Group 7
Hood • Front Fenders • Running Boards	Group 8
Heater • Air Conditioner • Firewall • Radio • Antenna	Group 9
Glass • Doors • Cowl • Weatherstrip • Wiper • Dash	Group 10
Rear 1/4 Glass • Seats • Door Sills • Dome Lenses	Group 11
Rocker Panels • Rear Sheet Metal • Deck Lid.....	Group 12
Convertible Tops and Parts	Group 13
Door Panels • Misc. Interior • Headlinings	Group 14
Carpet • Floor Mats • Trunk Linings	Group 15
Literature.....	Group 16

-ATTENTION-

This catalog pertains to
1930's and Up All models ONLY

We also have catalogues and stock Buick parts for:

1961 and Up Special, Skylark, Sportwagon and Gran Sport

1961 and Up LeSabre, Invicta, Wildcat, Electra 225,
Centurion, Century and Apollo

1973 and Up Regal, Grand National, T-Type and GNX

Please inquire about separate catalogs for the above Buicks

www.oldbuickparts.com

All rights reserved. No part of this publication may be reproduced without prior written permission from CARS, Inc. Illustrations in this catalog are representations only and may not exactly depict any particular part or part number. Prices subject to change without notice.



We Rebuild:

Alternators

Brake Boosters

Brake Shoes

Carburetors

Convertible Top Pumps

Drive Shaft Supports

Generators

Motor Mounts

Pressure Plate Assembly

Rocker Assembly

Starter Motors

Voltage Regulators

Wheel Cylinders

Ball Joints

Brake Cables

Camshafts

Clutch Discs

Distributors

Fuel Pumps

Master Cylinders

Oil Pumps

Transmission Mounts

Shocks

Vacuum Advances

Water Pumps

Vacuum Wiper Motors

Please Inquire.

We are a full service company.



CARS, LLC

205 Pearl St. • Neshanic Station, NJ 08853

(908) 369-3666 • (908) 369-7595 Fax

www.oldbuickparts.com

Motor Mounts Sold Outright



1933-1938 Front Motor Support Pads.
1933-1936 All (2 pair needed)
1937-1938 All (1 pair needed)
 MM368\$9.75 pr.

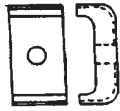

1934-1938 Front Motor Mounts.
1934-1935 Specials;
1936 All Except Convertibles,
1937-1938 All.
 MM367\$89.50 pr.

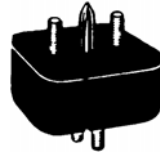

1948-1953
1948-1952 All;
1953 Specials.
 MM483.....\$77.50 pr.

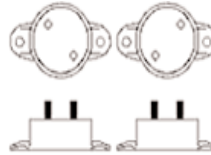

1953 All V-8 Engines.
 MM53\$77.50 pr.

1954-1956 All V-8 Engines.
 MM546\$77.50 pr.

Motor Mount Rebuilding Service (0.027)

We now offer you complete revulcanization of your motor mounts. Fresh, new rubber will insure safe and smooth running. The mounts listed below are sold on an exchange basis only. If we have your needed mount ready to ship we will charge you an additional core deposit of \$50.00 per item. This charge is fully refundable upon receiving your rebuildable cores. We prefer you send your mounts for rebuilding. Please allow at least 2 weeks for this process. See NOS section, Group .027 for outright sales.



1934-1935 Series 50 and 60. Front.
 Series 50 - 2nd type after frame #2727014;
 Series 60 - used after frame #2728021.
 MM345FRS.....\$134.50 pr.

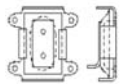

1934-1935 Series 40. Rear.
 1934 All series 40.
 1935 All Series 40 up to frame #2789239.
 MM345RS\$381.00 pr.

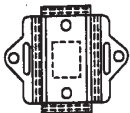

1935 Series 50. Rear.
 MM35RS\$146.50 pr.

1935 Series 60 (Century) Rear.
 MM35CRS\$126.75 pr.

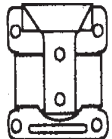

1935-1936. Rear.
 1935 Series 40 after frame #2789239.
 1936 series 40 all exc. model 46C.
 MM356RS\$211.50 pr.

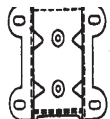

1936 Series 80-90 exc. 80C. Rear.
 MM36BRS.....\$285.50 pr.

1936 Series 60. Closed Body Styles.
 MM36RS\$238.00 pr.



1937-1938 Special. Rear Motor Mounts.
 MM378RS\$226.75 pr.



1937-1938 Century and Roadmaster. Rear Motor Mounts.
 MM378BRS.....\$252.75 pr.

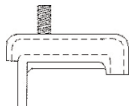

1939 Special and Century. Front motor mounts.
 MM39FRS.....\$167.75 pr.

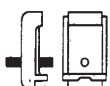

1939 Series 80-90. Front Motor Mounts.
 MM39BRS.....\$144.75 pr.

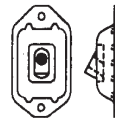

1939 All Rear Motor Mounts.
 MM39RS\$174.75 pr.

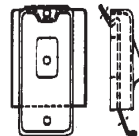

1940 Special and Century, Rear.
 MM40SRS.....\$200.00 pr.

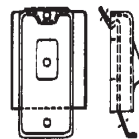

1940 Super and Roadmaster. Rear Motor Mounts.
 MM40BRS.....\$198.75 pr.

1940 Series 80-90. Rear Motor Mounts.
 MM40LRS\$208.25 pr.

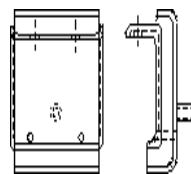

1940-1947 Front, Except Series 90.
 (Sold Outright - no core charge)
 MM407.....sold outright.....\$99.00 pr.
 MM407RS.....rebuilding service.....\$148.75 pr.

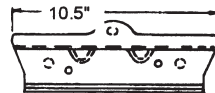

1941-1942 Series 90. Front Motor Mounts.
 MM412RS\$123.25 pr.

1941-1947 Rear Motor Mount.
 MM417RS.....\$118.25 ea.



1957-1958 All Front.
 Sold outright, No core charge.
 MM578.....\$111.00 pr.
 MM578RS.....rebuilding service.....\$128.75 pr.



1959-1960 All Front.
 Sold outright, No core charge.
 MM590\$75.50 pr.

Exhaust Valves (.0297)

1931-1935 Series 60;	
1936-1952 Roadmaster, Century and Limited.	
EV362.....	\$16.25 ea.
1936-1953 Special and Super.	
EV363.....	\$16.25 ea.
1953 All V-8.	
EV53.....	\$16.25 ea.
1954 All.	
EV54.....	\$16.25 ea.
1955 Exhaust Valve.	
EV55.....	\$16.25 ea.
1956 Exhaust Valve.	
EV56.....	\$16.25 ea.
1957-1958 Exhaust Valve.	
EV578.....	\$16.25 ea.
1959-1960 With 401 Engine.	
EV596.....	\$16.50 ea.



(.303) Valve Springs (.306)

1937-1947 All;	
1948-1949 Special and Super;	
1950 thru 1953 Special with Standard Trans. (outer).	
VS473.....	\$4.25 ea.
VS473S.....(Set of 16).....	\$65.00 set
1953-1960 All V-8. (inner).	
VS536.....	\$5.00 ea.
VS536S.....(Set of 16).....	\$58.00 set
1953-1960 All V-8. (outer).	
VS596.....	\$4.75 ea.
1953-1960 All V-8. Complete Set of 16.	
VS596S.....	\$52.25 ea.



Hydraulic Valve Lifters

1936-1953 All Mechanical Lifters. (Outright).	
VL360.....	\$16.50 ea.
1948-1953 All Straight-8 Engines. Hydraulic Valve Lifter. New, not rebuilt.	
VL483.....	\$19.25 ea.
VL483S.....Full Set of 16.....	\$319.00 set
1953-1955 Hydraulic Valve Lifters (Outright).	
VL535.....	\$11.25 ea.
1956-1960 Hydraulic Valve Lifters (Outright).	
VL567.....	\$9.50 ea.
VL567S.....Full Set of 16.....	\$139.50 set



Valve Spring Retainers (keepers) (.310)



1936-1965 All.	
VR365.....	\$3.00 pr.
Valve Spring Retainer Set	
VR365S.....(Set of 32).....	\$42.50 set

Intake Valves (.296)

1936-1952 Roadmaster, Century and Limited.	
IV362.....	\$16.25 ea.
1936-1953 Special and Super.	
IV363.....	\$16.25 ea.
1953 All V-8.	
IV53.....	\$16.25 ea.
1954-1956 All.	
IV546.....	\$16.25 ea.
1957-1958 All.	
IV578.....	\$15.75 ea.
1959-1960 With 401 Engine.	
IV596.....	\$14.25 ea.



Valve Guides and Seals (.283)

1934-1952 Series 40, 50;	
1953 Series 40 Exhaust and Intake Valve Guides.	
VG384.....	\$4.75 ea.
VG384S.....(Set of 16).....	\$69.50 set
1936-1952 320 Engines Exhaust and Intake Valve Guides.	
VG407.....	\$4.75 ea.
1953-1960 Intake and Exhaust Valve Guides. VG733.....	\$4.00 ea.
1953-1960 All V-8 Valve Stem Seals.	
VSS536.....	\$2.75 ea.



Valve Seat Inserts

1955-1956 All (Exhaust).	
VSI557.....	\$4.50 ea.
1957-1958 All (Exhaust).	
VSI572.....	\$4.50 ea.
1959-1960 All 364 and 401 Engines (Intake).	
VSI592.....	\$4.75 ea.
1959-1960 All 364 and 401 engines (Exhaust).	
VSI590.....	\$4.75 ea.

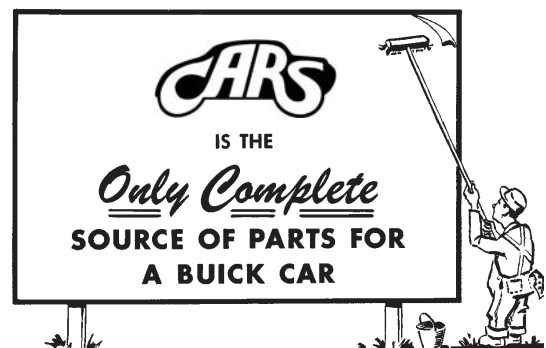

Engine Parts (Group 0)

Main Bearing Sets (.096)



Sets are available in standard 010, .020, .030, and .040 undersized. Please specify when ordering.

1937-1938 Special.	
MBS378.....	\$279.50 set
1937-1952 Series 60, 70, 80, 90.	
MBS372.....	\$232.50 set
1939-1950	
1939-1949: Special and Super;	
1950: Special.	
MBS390.....	\$222.50 set
1950-1953	
1950-1952: Super;	
1951-1953: Special.	
MBS503.....	\$147.50 set
1953-1956 All V-8.	
MBS536.....	\$139.00 set
1957-1960 All with 364 Engine.	
MBS571.....	\$126.50 set
1959-1960 All with 401 Engine.	
MBS596.....	\$159.50 set

Camshafts Regrinding Service

1935-1953 All Straight 8 Engines.	
CS353R.....	\$296.50 ea.
1957-1960 All Engines.	
CS576R.....	\$296.50 ea.



New Camshafts - Sold Outright (.519)

1953-1956 All V-8.	
CS536.....	\$324.00 ea.
1957-1960 All Engines.	
CS576.....	\$154.50 ea.
All Years. All Engines. Cam break-in lube.	
CL300.....	\$6.75 ea.

Connecting Rods (.603)

1959-1960 All with 401 Engine.	
CR596.....	\$43.25 ea.



Connecting Rod Bearings (.604)

1936-1950 248 Engines	
1936-1949: Special and Super;	
1950: Special.	
RBS360.....	\$94.50 set

1937-1952 Series 60, 70, 80, 90, 320 Engines	
RBS372.....	\$119.75 set

1950-1953 263 Engines	
1950-1952: Super;	
1951-1953: Special.	
RBS503.....	\$94.50 set

1953-1956 All V-8.	
RBS536.....	\$74.50 set

1957-1960 All.	
RBS576.....	\$89.50 set

Camshaft Bearings (.546)

1936-1953 All. Straight-8 Engines.	
CBS363.....	\$78.50 set

1953-1956 All. V-8 Camshaft Bearing Set.	
CBS536.....	\$78.50 set

1957-1960 All.	
CBS576.....	\$38.50 ea.



www.oldbuickparts.com

908-369-3666

Pistons (0.629)
We also have oversize pistons

1938-1950 All 248 Engines.
P380\$39.75 ea.
P380S.....(Set of 8).....\$268.50 set

1938-1952 All 320 Engines.
P382\$59.50 ea.
P382S..... (Set of 8).....\$429.50 set

1950-1953 All 263 Engines.
P503\$39.75 ea.
P503S.....(Set of 8).....\$268.50 set

1953 All 322 V-8 Engines.
P53\$43.00 ea.
P53S.....(Set of 8).....\$288.50 set

1954-1955 Special with 264 Engine.
P545.....\$59.50 ea.
P545S.....(Set of 8).....\$424.50 set

1954-1956 Super, Century, Skylark and Roadmaster with 322 Engine.
P546\$43.00 ea.
P546S.....(Set of 8).....\$288.50 set

**1957-1958 All;
1959-1961 LeSabre. 364 Engines**
P571\$43.00 ea.
P571S.....(Set of 8).....\$288.50 set

All others PLEASE INQUIRE

**Harmonic Balancer
Rebuilding Service**



Balancers are completely disassembled, shot peened and inspected. Threaded holes are repaired and new seal saver is installed. (non-rope seal apps.) New silicone rubber is injected, then vulcanized for proper bonding. Please remove any bolted pulleys before sending. For those not listed, please inquire.

1953-1956 All 322 V-8 Engines.
HB322RS\$154.00 ea.

1954-1955 All Special, 264 Engine. No Rubber Type.
HB264RS\$56.00 ea.

1954-1955 All Special, 264 Engine. Riveted Type.
HB264RRS.....\$154.00 ea.

1957-1960 All 364 Engine. Riveted. 75% of weight removed from ring. External Balanced.
HB364RS\$154.00 ea.

1959-1960 All 401 Engine. Riveted type.
HB401RS\$155.50 ea.

Piston Ring Sets (0.643)
We also have oversize rings

1937-1950 All 248 Engines.
PRS380\$109.00 set

1938-1952 All 320 Engines.
PRS382\$112.00 set

1951-1953 Special and Super with Straight-8 Engine.
PRS513\$99.50 set

1953-1956 All with 322 Engine, Cast Iron.
PRS322\$79.50 set

1953-1956 All with 322 Engine, Moly Set.
PRS322M\$117.00 set

1954-1955 All Special with 264 Engine.
PRS264\$92.50 set

1957-1960
1957-1958: All;
1959-1960: with 364. Cast Iron.
PRS364\$79.50 set

1957-1960
1957-1958: All;
1959-1960: with 364. Moly Set.
PRS364M\$129.50 set

1959-1960 All with 401 Engine, Cast Iron.
PRS401C.....\$94.50 set

1959-1960 All with 401 Engine, Moly Set.
PRS401M\$195.00 set

Push Rods (0.426)

1941-1949 Special with Solid Lifters. 12 13/16"
PR419\$15.50 ea.

1949 Super:
1950 Special. For Cars with Hydraulic Lifters. 11"
PR490\$15.50 ea.

1950-1953 For Dynaflo Cars.
1950-1952 Super;
1951-1953 Special .
PR503\$14.00 ea.

1950-1953 Special. All with Standard Transmission 12-1/8" length.
PR503S\$15.50 ea.

1953-1955 All V-8.
PR535\$7.25 ea.

1956 All.
PR56\$7.25 ea.

1957-1961 364 Engine.
PR573\$7.25 ea.
PR535S.....(Set of 16)\$74.25 set

1959-1960 All with 401 Engine.
PR597\$5.75 ea.
PR597S.....(Set of 16).....\$78.00 set

Engine Parts (Group 0)

Timing Chains (0.724)



- 1934-1949** Special;
1940-1949 Super.
 TC349.....\$91.50 ea.
- 1936-1949** Series 60, 70, 80, 90
 TC369.....\$84.75 ea.
- 1950-1952** Special and Super;
1953 Special. 49 Links.
 TC503.....\$78.50 ea.
- 1950-1952** Roadmaster.
 TC502.....\$78.50 ea.
- 1953-1960** All V-8.
 TC536.....\$34.50 ea.



Timing Chain Sets with Iron Cam Gear (Includes chain and 2 gears)

- 1934-1949**
1934-1938: Special;
1939-1949: All Special and Super.
 TS349.....\$179.50 set
- 1936-1949** Series 60, 70, 80 and 90.
 TS369.....\$169.50 set
- 1950-1952** Roadmaster.
 TS502.....\$189.50 set
- 1950-1953** Specials and Super with Straight-8 Engine
 TS503.....\$189.50 set
- 1953-1956** All V-8.
 TS536.....\$104.50 set
- 1957-1960** All.
 TS576.....\$108.50 set

Timing Chain Cover



- 1957-1960** All 364, 401,425.
New and Improved
 A beautiful high quality reproduction with improved oil passages, a modern front mounted neoprene seal already installed.
 Made In USA
 TC576.....\$299.00 ea.

Aluminum Valve Covers



- 1953-1960** All V-8 Engines. Grooved with "BUICK" as original. Nice reproduction! Matte finish. Includes oil cap, PCV grommet, bolts and gaskets
 AVC536\$199.00 pr.



- 1953-1960** All V-8 Engines. Grooved with "BUICK" as original. Nice reproduction! Bright finish. Includes PCV grommet, and gaskets only
 AVC536B.....\$199.00 pr.

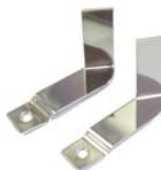

- 1963-1966** All with Aluminum Valve Covers. Chrome Plated.
 WRS636\$36.00 pr.



- "AC OIL" Chrome twist on cap.
 OC647.....\$31.00 ea.



ORDER BY PHONE!

908-369-3666

Rocker Arm Assembly Rebuilding Service

- 1937-1953** All Straight 8 Engines with mechanical or hydraulic lifters.
 RAA373\$390.50 ea.
- 1953-1958** All. V-8.
 RAA538\$353.00 pr.
- 1959-1960** All.
 RAA596\$296.50 pr.

Rocker Arm Shafts (.353)

- 1953-1960** All. V-8, rocker arm shaft.
 RS536\$48.50 ea.
 RS536P.....Pair.....\$88.50 pr.



Rocker Arms (0.333)

- 1953-1960** All V8 Reproduced in steel.
 Set includes 16 arms.
 RAS536\$208.50 set



Rocker Arm Adjusting Ball (0.276)

- 1924 thru 1952** All;
1953 Special. NOT for Hydraulic Lifter Applications.
 AB243.....\$4.25 ea.

- 1953-1955** V8 Rocker Arms
 RA536L.....L.H.....\$16.00 ea.
 RA536R.....R.H.....\$16.00 ea.

Valve Cover and Spark Plug Cover Hardware (.416)



- 1934-1938 series 40;**
1936-1953 All. Straight 8 Engines. Rocker Cover Studs.
 RS343\$4.25 ea.

- 1934-1935 series 40;**
1936-1940 All. Straight 8 Engines. Spark Plug Cover Studs.
 CS340\$4.00 ea.



- 1936-1955** Rocker Cover Nuts.
 (Also fits 1939-1953 Spark Plug Covers).
 RN395\$3.00 ea.
 W6.....\$.50 ea.
 (Fiber washer for use under RN395)



- 1953-1956** Spark Plug Cover Nuts.
 Also fits Rocker Covers. (.416)
 SN536\$3.00 ea.
 W6\$.50 ea.
 (Fiber washer for use under SN536)



- 1957-1960** Valve Rocker Cover Bolt Grommet. (4 per car).
 VCG572\$3.50 ea.



Freeze Plug Kits (.553) (enough for complete overhaul)

- 1927-1953** All. Straight 8.
 FPK273\$17.50 kit
1953-1960 All V-8.
 FPK536\$18.50 kit

Cars, Inc. World Leader in

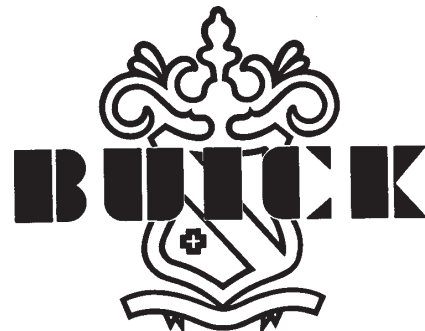

Parts & Service

Engine Parts (Group 0)

Clutch Parts (0.886)

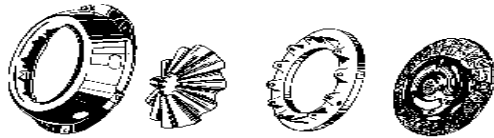

Clutch Pressure Plate Replacement Kit

1939-1955

1939 -1955: Series 40;

1939 -1953: Series 50.

Includes NEW Clutch, Pressure Plate, throw out bearing (old collar must be used) Pilot bearing and alignment tool.

Features improved 10 1/2" clutch disc.

CPA395.....\$285.00 kit

Clutch Disc Rebuilding Service

1931-1937

1931-1935: Series 50;

1934-1937: Series 40.

CD317.....10" - 1 1/4.....\$98.50 ea.

1931-1935 Century. 9 7/8" - 1 1/2".

CD315.....\$98.50 ea.

1936-1937 Series 60, 70, 90.

CD367.....11" - 1 1/4.....\$98.50 ea.

1938 Special.

CD38.....10" - 1 1/8".....\$97.50 ea.

1938-1948 10 1/2" - 1 1/8" discs. Series 60, 70, 80 and 90.

CD388.....\$97.50 ea.

1939-1955 All. 10" x 1 1/8".

1939-1952: Special and Super;

1953-1955: Special.

CD395.....\$97.50 ea.

CD395R.....New Replacement.....\$89.50 ea.

1953-1960

1953-1955: Super and Century;

1956-1960: All.

CD530.....\$97.50 ea.

Clutch Release Support

1940-1955 All.

Coming Soon

Clutch Pressure Plate Assembly Rebuilding Service

1934-1956 All.

PP366.....\$167.75 ea.

1957-1963 All.

PP573.....\$197.50 ea.

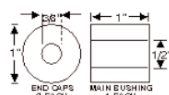

1941-1953 All Standard trans. Kit, clutch equalizer. Kit includes metal sleeved rubber bushing and 2 end seals. (0.806)

EB413.....\$37.25 kit

1941-1949 All models. Bumper, clutch pedal stop at toe board. (.832)

PS419.....\$12.00 ea. 8

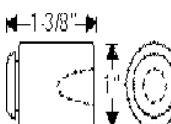

Clutch Arm Boot

1940-1955 All.

CB405.....\$12.50 ea.



Clutch Throw Out Bearings (.799)

1932 thru 1935 series 50;

1936 series 60-80-90;

1937 All.

TB327.....\$79.50 ea.



1938 All.

TB38.....\$51.00 ea.



1939-1955

1939-1952: All Special and Super;

1953-1955: All Specials.

TB395.....(Bearing only).....\$37.50 ea.

TB395A.....(Assembly).....\$94.50 ea.



1939-1960 Bearing

1939-1952: Series 60, 70, 80 and 90;

1953-1955: Super and Century;

1956-1960: All.

TB416.....\$41.25 ea.



Clutch Pilot Bearings (.649)

1932-1956

1932-1933 series 50;

1934-1935 series 40,50;

1936-1956 All. Except 1938 Specials and 1939.

PB366.....\$19.50 ea.



1938 Special; 1939 all.

PB389.....\$19.50 ea.



1957-1960 Clutch pilot bearing.

PB570.....\$8.00 ea.

Stop Light Switches (2.447)

1936-1940 All.

SLS360.....\$17.50 ea.



1941-1955 All.

SLS415.....\$9.75 ea.



1956-1960 All.

SLS563.....\$9.75 ea.



1936-1980 Brake adjuster hole plug. (4 per car).

BC340.....\$1.00 ea.



1936-1958 All, brake and clutch pedal return grommets.(9.775) (2 per car)

PG365.....\$7.75 ea.





Decal and Detail Kits

This kit includes 15-23 decals but is not limited to Valve Covers, Glove Box, Jack Instruction, Oil Filter and Air Cleaner decals. Priced to **SAVE!**

Sets include decals that originally came with car. Standard equipment only.

DK36	1936	\$44.00
DK37	1937	\$49.00
DK38	1938	\$49.00
DK39	1939Series 50, 60, 70.....	\$49.00
DK39S	1939Series 40.....	\$49.00
DK40	1940Series 50, 60, 70.....	\$49.00
DK40S	1940Series 40.....	\$49.00
DK41	1941Black value cover decal.....	\$49.00
DK42	1942	\$49.00
DK46	1946	\$49.00
DK47	1947	\$49.00
DK485	1948Special & Super	\$49.00
DK48	1948Roadmaster.....	\$49.00
DK49	1949	\$49.00
DK50	1950	\$49.00
DK51	1951	\$49.00
DK52	1952	\$49.00
DK53	1953Series 70 & Skylark.....	\$49.00
DK534	1953Super.....	\$49.00
DK53S	1953Series 40.....	\$33.00
DK54T	1954All 2BBL Models.....	\$36.50
DK55T	1955All 2BBL Models.....	\$34.50
DK56T	1956All 2BBL Models.....	\$34.50
DK57T	1957All 2BBL Models.....	\$34.50
DK58T	1958All 2BBL Models.....	\$34.50
DK59T	1959All 2BBL Models.....	\$34.50
DK60T	1960All 2BBL Models.....	\$34.50
DK54F	1954All 4BBL Models.....	\$36.50
DK55F	1955All 4BBL Models.....	\$34.50
DK56F	1956All 4BBL Models.....	\$34.50
DK57F	1957All 4BBL Models.....	\$35.00
DK58F	1958All 4BBL Models.....	\$35.00
DK59F	1959All 4BBL Models.....	\$35.00
DK60F	1960All 4BBL Models.....	\$35.00

Individual kit decals are not returnable.



D37



D40



D41

Owners Manual Envelopes

D37	1936-1940	\$3.50
D38	1941	\$3.25
D39	1942-1950	\$3.25
D40	1951-1954	\$3.25
D41	1955-1957	\$3.25
D145	1958 All(Beautifully Embossed).....	\$5.75

Engine Compartment Decals/Tags

D1	1931-1960	Generator Warning Tag	\$2.00
D86	1936-1960	Antifreeze Tag.....	\$2.50
D19	1937-1953	Oil Filler Cap Decal.....	\$3.25
D31	1941-1958	Trico Washer Pump Decal	\$4.50
D202	1941-1958	GM Windshield Washer Bracket Decal	\$3.75
D22	1952-1956	Power Steering Pump Decal	\$3.50
D230	1941-1958	GM Auto. Windshield Washer Decal (yellow).....	\$4.50
D375	1954-1960	Electric Antenna.....	\$4.50
D172	1954-1960	Air Conditioning Compressor Warning Decal.....	\$5.00
D72	1955-1960	Harrison A.C. Tag Metal	\$5.75
D296	1959-1960	Optikleen Bottle Label.....	\$3.00
D178	1959-1960	Cooling System Decal.....	\$5.00
D370	1960	New Car Price Booklet	\$3.50



D1



D5



D71

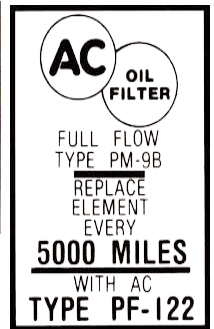

D74

Oil Filter Decals

D3	1930-36	A.C. (W6).....	\$3.50
D4	1937-47	A.C. (L1)	\$4.00
D5	1949-53	A.C. (P127).....	\$3.75
D73	1946-48	"A.C."	\$4.00
D74	1953-58	A.C. (PF122).....	\$4.00



D 108



D 112



D 117



D 111



D310



D 118

Garage Wall, Tool Box Decals

D108	Old Style Buick Logo (blue and white).....	\$8.50
D111	"Genuine Buick Parts" 2" x 2 1/2" Water Transfer..	\$1.50
D112	"Buick 8" 2" x 2 1/2" Water Transfer.....	\$1.50
D117	"Authorized Service" (10" diameter red, white and blue decal).....	\$8.50
D118	"Authorized Service" (5" diameter red, white and blue decal).....	\$6.50
D310	Tri-Shield 12" (red, white and blue).....	\$9.75
D379	1953-1960 "Air Conditioned" window decal.....	\$5.00
D75	"Authorized Buick" Lube Sticker.....	\$2.25

Buick Decals • Tags • Etc. (Group 0)



D10

D12



D21



D16



D17

Valve Cover Decals

- D6 1936-37 "Valve/Head Silent Oil Cushion"\$7.25
- D19 1937-1953 Oil Filler Cap decal (silver).....\$3.25
- D7 1938 "Buick 8 Dynaflash Oil Cushion"\$7.25
- D8 1939-1940 Ser. 40 "Dynaflash Oil"\$7.25
- D9 1939-1940 Ser. 60-70 " Dynaflash Oil"\$7.25
- D10 1941-1953 "Valve in Head Fireball".
- D10B 1941-1947 All:
 - 1948 Exc Ser. 70 Black
 - D10U 1942-1948 Some. Blue
 - D10R 1948 Ser. 70;
 - 1949- S2911; 53 Ser. 40 Red.....\$7.25
- D21 1948-1953 "Hydraulic Lifter" decal.....\$4.75
- D13 1950-1953 263 Cubic Inch decal\$4.50
- D12 1953-1955 V8 w/ raised covers. (set of two).....\$6.50
- D184 1953-60 V-8 Oil Filler Cap decal (orange)\$3.00



D30



D44



D165

Interior Decals/Tags

- D24 1936 Glove Box Tire Pressure\$2.75
- D23 1936-1960 Owners I.D. Card\$3.25
- D76 1936-1937 Battery Warrantee\$3.50
- D208 1936-1954 Buick Service Policy.....\$3.25
- D30 1934-1958 Glove Box Key Sticker\$2.75
- D25 1937 Glove Box Tire Pressure\$2.75
- D81 1937-1953 Tire and Wheel Balance Tag\$3.25
- D82 1937-1953 Oil and Tire Instruction Tag.....\$2.75
- D79 1937-1960 Compass Directions\$3.50
- D367 1937-1960 New Car Break-in Tag\$3.50
- D26 1938 Glove Box Sticker.....\$2.75
- D27 1939-1947 Glove Box Sticker\$2.75
- D209 1939-54 Buick Battery Warranty Cert.\$3.50
- D206 1940 Electric Clock Instructions\$3.50
- D207 1940 Buick New Car Inspection/Adjustment Sheet\$2.50
- D211 1940-1954 Chrome Care Instructions\$3.50
- D71 1940-1963 Casco Auto. Lighter Tag Interior Decal.....\$4.00
- D28 1948-1950 Glove Box Sticker\$2.75
- D29 1951-1954 Glove Box Sticker\$2.75
- D385 1955-1960 Battery Certificate\$3.00
- D44 1956-1960 Glove Box Door Sticker.....\$4.00
- D124 1957-1958 2-Speed Windshield Wiper Tag.\$4.25
- D165 1957-1960 Glove Box "Lacquer Paint".....\$3.50
- D36 1958-1959 Autronic Eye Instructions\$4.50



D85

Air Cleaner Decals

- D14 1935-1936 (Dry Element).....\$4.25
- D20 1936-1946 Oil type or Dry style warning (Oval) ..\$4.00
- D15 1936-1946(Oil Bath Type).....\$4.00
- D419 1931-1934 Dry style air cleaner\$4.50
- D16 1946-1953 (All straight 8); 1953 Super\$4.50
- D17 1953-1957 4bbl. Carb. (orange. Oil Bath Type) ..\$4.00
- D16 1954-1956 2bbl. Carb. (orange).....\$4.00
- D18 1957 2BBL Oil Bath Type (white).....\$4.00
- D173 1958 2bbl. Air Cleaner (white).....\$4.75
- D162 1958 4 bbl. Air Cleaner decal (red)\$4.50
- D174 1958 4 bbl. Air Poise Suspension decal (red).....\$5.00
- D85 1959-1960 Wildcat 445 (2 piece set on lid).....\$12.25
- D368 1959-1960 4bbl Service Inst. on side. A63C\$4.50
- D182 1959-1960 2bbl Service Inst. on side. A86C.....\$4.50

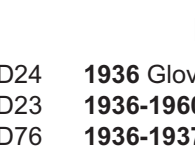

D33

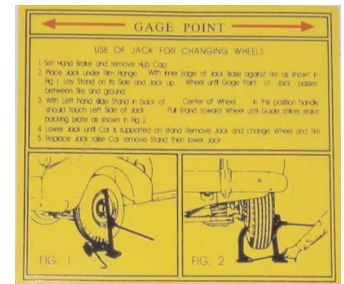

D93

Trunk Decals/Tags

- D93 1938-1941 Jack Instructions\$3.00
- D110 1942-1948 Jack Instructions\$3.00
- D245 1949 Jack Instructions\$4.50
- D32 1955 Jack Instructions\$4.00
- D33 1956 Jack Instructions\$3.00
- D34 1957 Jack Instructions\$4.50
- D113 1958 Jack Instructions\$4.50
- D35 1958-1960 Air Suspension.....\$4.50
- D356 1959 Jack Instructions\$4.25
- D170 1959-1960 Jack Decal (on Jack).....\$4.50
- D360 1960 Jack Instructions\$4.25

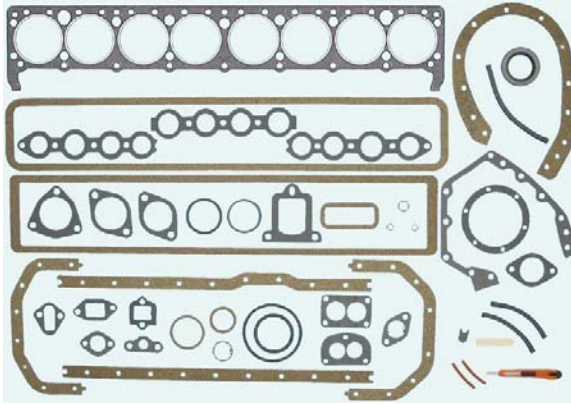

Full Engine Gasket Sets, Head Rebuilding Sets and Head Gaskets

1931-1935 Series 50, 60, 80, 90. Inc composition head gasket.
 FGS315.....Full Rebuilding Set.....\$325.00 ea.
 HG315.....Head Gasket, Series 50.....\$84.50 ea.
 HG315B.....Head Gasket Series 60, 80, 90.....\$97.50 ea.

1934-1949 All Special and Super;
1950 Special. for 233 and 248 engines. prg-346 not included.
 FGS340.....Full Rebuilding Set.....\$145.00 ea.
 HGS349.....Head Rebuilding Set.....\$95.50 ea.
 HG349.....Head Gasket Only.....\$59.50 ea.

1950-1953 All Special and Super. 263 engines.
 FGS503.....Full Rebuilding Set.....\$137.50 ea.
 HGS503.....Head Rebuilding Set.....\$99.50 ea.
 HG503S.....Head Gasket Only. .015.....\$59.50 ea.

1936-1952 Series 60, 70, 80, 90. 320 engines.
 FGS362.....Full Rebuilding Set.....\$189.50 ea.
 HGS362.....Head Rebuilding Set.....\$95.50 ea.
 HG362.....Head Gasket Only. .015.....\$63.50 ea.

1953-1953 All V-8 engines. Includes .045 head gaskets.
 *FGS536.....Full Rebuilding Set.....\$139.00 ea.
 HGS536.....Head Rebuilding Set.....\$89.50 ea.
 HG536.....Head Gaskets Only.....\$52.50 pr.

1953-1953 All V-8 engines. Includes .015 head gaskets.
 *FGS536S.....Full Rebuilding Set.....\$115.00 ea.
 HGS536S.....Head Rebuilding Set.....\$89.50 ea.
 HG536S.....Head Gaskets Only.....\$52.50 pr.

1957-1960 All V-8 engines. Includes .045 head gaskets.
 *FGS576.....Full Rebuilding Set.....\$129.50 ea.
 HGS576.....Head Rebuilding Set.....\$74.50 ea.
 HG576.....Head Gaskets Only.....\$67.50 pr.

* Contains new "rubber lip" timing cover seal!



Timing Cover Gasket Sets

1934-1941 All 248 and 263 straight-8 engines.
 TCS341.....(includes rope seal).....\$26.00 ea.
1942-1953 All 248 and 263 straight-8 engines.
 TCS423.....(includes rubber lip seal).....\$29.50 ea.
1942-1949 All 320 Roadmaster straight-8 engines.
 TCS429.....(includes rubber lip seal).....\$26.00 ea.
1950-1952 All 320 Roadmaster straight-8 engines.
 TCS502.....(includes rubber lip seal).....\$29.50 ea.
1953-1960 All V-8.
 TCS536.....(includes rubber lip seal).....\$19.50 ea.

Timing Cover Gaskets and Seals

1934-1953 All 248 and 263 straight-8 engines. Cover gasket.
 BG13022.....(cork/rubber gasket).....\$9.50 ea.
1934-1953 All 248 and 263 straight-8 engines. Back plate.
 BG10038.....(paper gasket).....\$7.75 ea.
1936-1952 All 60, 70, 80, 90, 320 Engines. Cover gasket.
 BG13023.....(cork/rubber gasket).....\$9.50 ea.
1936-1952 All 60, 70, 80, 90, 320 Engines. Back plate.
 BG10037.....(paper gasket).....\$6.50 ea.
1937-1953 All straight-8 engines. Front rope seal.
 BG7056.....\$9.50 ea.
1942-1953 All 248 and 263 straight-8 engines;
1942-1949 All 60, 70, 80, 90, 320 Engines. Modern lip seal.
 BG3494.....\$19.50 ea.
1950-1952 Roadmaster, 320 Engines. Modern lip seal.
 BG3495.....\$14.50 ea.
1953-1960 All V-8. Cover gasket.
 BG12060.....\$9.50 ea.
1953-1960 All V-8. Front seal. Modern lip seal.
 TCS536L.....\$11.75 ea.

Rear Main Seals

1934-1953 All straight-8 engines;
1957-1960 All. Rear main rope seal.
 RMS346.....\$15.50 ea.
1939-1953 All. Special and Super; **1953** Special. Lip seal.
 RMS343M.....\$39.50 ea.
1953-1956 All. V-8 engines. Rope seal set.
 RMS536.....\$16.00 ea.
1957-1960 All. V-8 engines. Rubber lip type seal.
 RMS576.....\$19.50 ea.

Distributor Base Gaskets

1934-1952 All; **1953** Special. Crankcase vent gasket.
 BG4225.....\$4.50 ea.
1934-1952 All; **1953** Special. Distributor base gasket.
 BG1272.....\$3.50 ea.
1953-1960 All V-8. Distributor base gasket.
 BG1634.....\$3.50 ea.

Engine Gaskets (Group 0)



Valve Cover Gaskets

- 1934-1953;**
1934-1952 All Special and Super;
1953 Special.
 VCG343.....\$16.95 ea.
1936-1952 All Series 60, 70, 80, 90. 320 engines.
 VCG362.....\$16.95 ea.
1953-1960 All V-8 engines.
 VCG536.....\$16.50 pr.
 VCG572.....(Bolt grommets, 4 needed).....\$3.50 ea.

Push Rod Cover Gaskets

- 1934-1936** All Series 40.
 PRG346.....\$16.50 ea.
1937-1949 All Special and Super;
1950 Special.
 PRG370.....\$15.00 ea.
1951-1953 All Special.
1950-1952 Super.
 PRG503.....\$15.00 ea.
1936-1952 All Series 60, 70, 80, 90. 320 engines.
 PRG362.....\$15.00 ea.
1936-1953 All straight-8 engines. Push rod nut gasket.
 PRG363.....(8 req. per car).....\$1.00 ea.









- 1953-1956** All V-8 engines.
 PRG536.....\$9.75 ea.
1957-1960 All V-8 engines.
 PRG576.....\$9.75 ea.

Misc. Oil Gaskets

- 1934-1958** All engines. Oil pan drain plug gasket.
 ODG348.....\$2.50 ea.
1934-1952 Special & Super; **1953** Special. Oil pump cover.
 BG3381.....\$4.50 ea.
1934-1952 Special & Super; **1953** Special. Oil pump/block.
 BG3292.....\$4.50 ea.
1936-1952 Ser. 60, 70, 80, 90. 320 engines. Oil pump mtg.
 BG3871.....\$4.75 ea.
1953-1956 All V-8 engines. Oil pump inlet. Tri-angular.
 BG3484.....\$4.75 ea.
1953-1960 All V-8 engines. Oil pump body.
 BG2380.....\$4.75 ea.
1953-1960 All V-8 engines. Oil filter housing to block.
 BG3486.....(except 1957-1958).....\$4.75 ea.
 BG3595.....(1957-1958 only).....\$4.75 ea.
1953-1960 All except 1959. Oil pump inlet.
 BG2324.....(All except 1959).....\$4.75 ea.
 BG1479.....(1959 only).....\$4.75 ea.
1957-1958 All engines. Oil pump body.
 BG2469.....\$4.75 ea.

Thermostat Related Gaskets

-  **1933-1953** All straight 8 engines. Water outlet.
 WOG330.....\$2.50 ea.
 **1934-1940** All Special and Super. Thermostat housing.
 BG2172.....\$2.75 ea.
 **1936-1940** All 60, 70, 80, 90 320 engines;
1941-1949 All engines. Thermostat housing.
 BG2173.....\$2.75 ea.
 **1950-1953** All straight 8 engine. Thermostat housing/head.
 BG3386.....\$2.75 ea.
 **1934-1953** All straight 8 engines. Therm. Hsg. bolt seals.
 BG134.....(2 needed per car).....\$1.00 ea.
 **1953-1960** All V-8 Engines. Water outlet.
 WOG536.....\$2.25 ea.

Water Pump and Manifold Gaskets

- 1934-1940** All Special and Super. Water pump backing plate.
 WPG340.....\$6.50 ea.
1941-1953 All straight-8 eng. Water pump backing plate.
 WPG413.....\$6.50 ea.
1934-1940 All Special and Super. Water pump to block.
 BG2204.....\$2.50 ea.
1936-1940 All 60, 70, 80, 90 320 engines w/ pump to block;
1941-1949 All engines water pump to block;
1950-1953 All straight-8. Water pump to elbow.
 BG2140.....\$2.50 ea.
1950-1953 All straight-8 eng. Water pump elbow to block.
 BG3015.....\$3.00 ea.
1953-1955 All V-8 engines. Water pump mounting gasket.
 WPG535.....\$4.50 ea.
1953-1960 All V-8 engines. Water manifold seal kit.
 Contains two end gaskets and center "o" ring.
 WMK536.....\$8.50 ea.
1956-1960 All V-8 engines. Water pump mounting gasket.
 WPG561.....\$4.75 ea.



Oil Pan Gaskets

- 1934-1952** All Special and Super; **1953** Special.
 OPG343.....\$16.25 ea.
1936-1952 All series 60, 70, 80, 90. 320 engines.
 OPG362.....\$16.25 ea.
1953-1956 All V-8 engines.
 OPG536.....\$13.50 ea.
1957-1960 All V-8 engines.
 OPG576.....\$14.50 ea.

Original Colors to Authenticate your Engine.
 Our Enamels are the Finest available. Heat
 Resistant to 700° F. Can be Easily Brushed or
 Sprayed to Obtain a Rich Deep Gloss.
 Sold in Quart or Spray Cans.

* Note: Spray cans can NOT be shipped by Air.

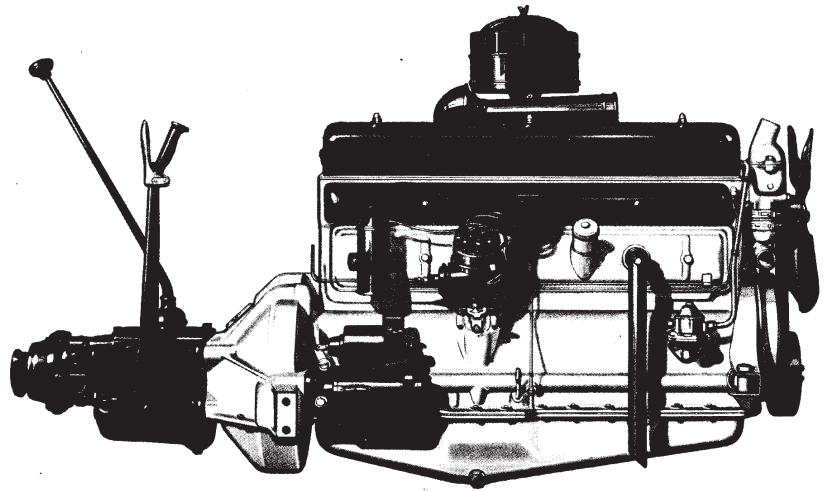

Please Note:
 Spray Cans cannot be shipped by Air.



YEARS	APPLICATION	Quart Cans	12 oz. Spray Can
1932	Black	EP1.....\$24.50	EP1S\$14.00
1933-1938	Forest green engine paint	EP298.....\$27.50	EP298S\$14.00
1939-1940	Gray engine paint	EP390.....\$27.50	EP390S.....\$14.00
1941	Dante red engine paint	EP41.....\$27.50	EP41S\$14.00
1942-1952	Turquoise engine paint	EP423.....\$27.50	EP423S\$14.00
Also 1953	Series 40 buick turquoise	EP536.....\$27.50	EP536S.....\$14.00
1953-1960	All V8 buick green		



Spray Gun for Engine Enamels

Self-propelled unit enables you to spray up to 16 oz. of paint. Great for use on engine enamels listed above that are not available in spray cans.

SG220.....\$12.50 ea.
 Refill cartridge.
 SGR220\$6.50 ea.

Engine Compartment and Chassis Paint

All years satin black paint. This is correct enamel for frame and engine compartments. Authentic for all years. Excellent for use on fan, radiator, air cleaner, side pans, shroud, etc.

EP2.....(Quart).....\$24.50 ea.
 EP2S.....(12 oz. spray can)\$14.00 ea.

Cast Iron Paint

Extremely High Temperature - 1800 degrees. Excellent for manifolds and exhaust systems. **Will not burn OFF.**
 EP3.....(pint).....\$32.00 ea.
 EP3S.....(spray can).....\$19.50 ea.

All years universal gloss black. Excellent for engine dress-up, chassis and general use.

EP1.....(Quart).....\$24.50 ea.
 EP1S.....(12 oz. spray can)\$14.00 ea.



Optional Dante Red Wheel Paint

Our EP41 and EP41S is also used as a correct replacement for the optional wheel color - Dante red used from 1938 thru 1960.